

REGENT VL71I



FEATURES AND BENEFITS

Lightweight Stainless Steel Construction • High efficiency symmetrical reflector • Stainless steel cover with quick release fasteners

CERTIFICATION & APPROVALS

Ingress protection IP66 and IP67
to EN60529

Designed & manufactured
to EN60598-1

DIMENSIONS

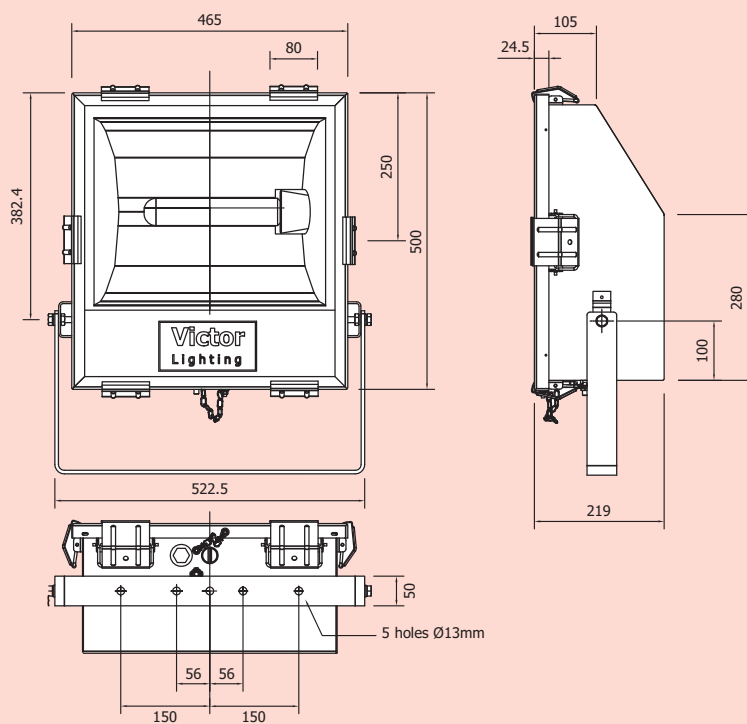

Dimensions in millimetres

ORDERING REFERENCE

Std. Cat Ref.	Wattage	Lamp Type	Lampholder
REGI/150/MS	150W	HPS/Metal Halide	E40
REGI/250/MS	250W	HPS/Metal Halide	E40
REGI/400/MS	400W	HPS/Metal Halide	E40
REGI/500/TH	500W	Tungsten Halogen	E40
110/120V Cat Ref.			
REGI/150/MS/120**	150W	HPS/Metal Halide	E40
REGI/250/MS/120**	250W	HPS/Metal Halide	E40
REGI/400/MS/120***	400W	HPS/Metal Halide	E40

** c/w IEC control gear 110/120V supply

*** c/w Transformer box for 110/120V supply (IEC control gear fitted)

TECHNICAL SPECIFICATION

LAMP TYPES

SON/MBI = 150W, 250W, 400W (Tubular)
Tungsten Halogen = 500W

POWER SUPPLY

220V, 230V, 240V, 254V 50Hz

POWER FACTOR

Better than 0.85

TERMINALS

3 core up to 6 mm² conductors with looping. Terminals for live constant, neutral & earth are provided. Internally earthed, external earth terminal as standard.

CABLE ENTRIES

2 x M20 cable entries.
Supplied with 1 x transit plug and 1 x blanking plug.
Cable entry devices (i.e. glands) must maintain the IP rating of the luminaire.

TEMPERATURE

Refer to matrix above for maximum ambient temperature for lamp, T rating & orientation.

MATERIALS

Main Body	Epoxy painted marine grade stainless steel.
Lampglass	Toughened glass.
Gasket	Silicone rubber.
External Fasteners	Stainless steel.

WEIGHT

150W - 19Kg
250W - 20.5Kg
400W - 21Kg
500W - 16.5Kg
110/120V - 23Kg

MOUNTING

Stainless steel stirrup bracket.

OPTIONS - SUFFIX TO CATALOGUE REF.

/60	60Hz
/M25	M25 Entries
/TI	Timed cut-out ignitor
/WA	Suitable for wire guard or anti-glare shield
/N	Narrow beam reflector

ACCESSORIES

Wire guard
S8644-0004
(Requires /WA suffix when ordering)

Pole mount bracket
S2400-0002

Spigot mount bracket
S2400-0007

Anti-glare shield
S8644-0002
(Requires /WA suffix when ordering)