

VANGUARD VL34 & VL35 EMERGENCY MODELS

INSTALLATION, OPERATION AND MAINTENANCE INSTRUCTIONS

Important: Please read these instructions carefully before installing or maintaining this equipment. Good electrical practices should be followed at all times and this data should be used as a guide only.

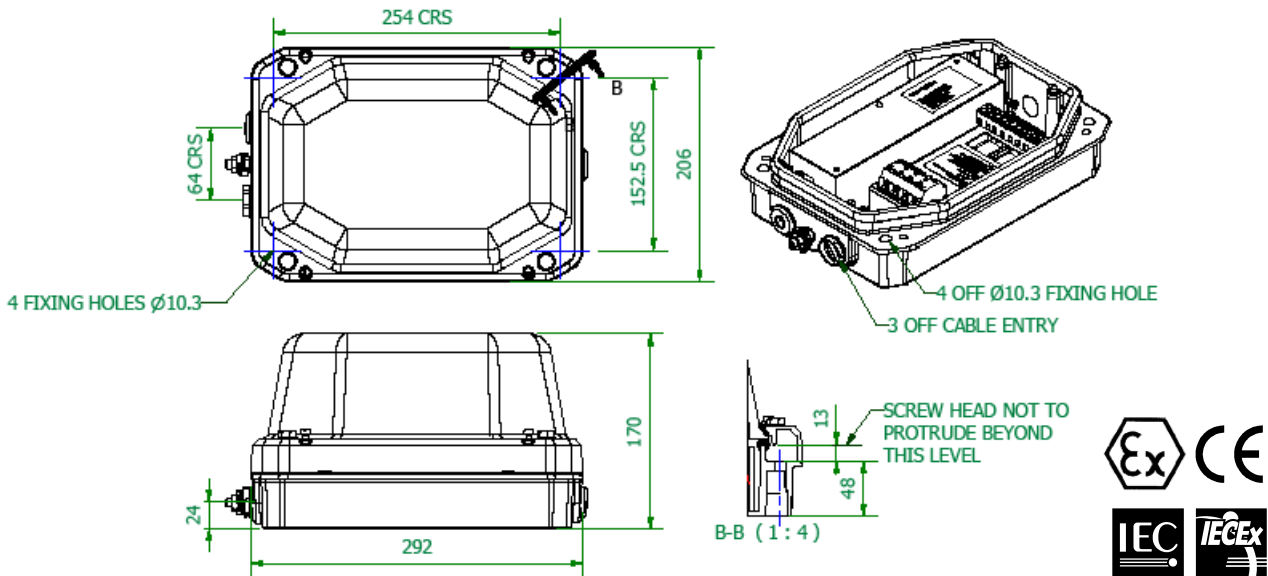

Type of Protection	Ex e ib mb (Increased safety, intrinsic safety and encapsulated), Ex tD (dust)
Protection Standards	IEC60079-0:2007 / EN60079-0:2006, IEC60079-7:2006 / EN60079-7:2007 , IEC60079-11:2006 / EN60079-11:2007, IEC/EN 60079-18:2004, IEC/EN 61241-1:2004
Area Classification	Zone 1 and Zone 21 areas to EN/IEC 60079-10, EN/IEC 61241-10
Installation	EN/IEC 60079-14 and EN/IEC 61241-1-2.
Certificate	EC Type Examination Certificate: Baseefa08ATEX0102X IEC certificate of conformity: IECEx BAS 08.0038X
Equipment Coding	Ex e ib mb IIC T4 Gb -45°C ≤ Ta ≤ +55°C Ex tD IIIC T100°C Db II 2GD
Ingress Protection	IP66 and IP67 to EN/IEC 60529
Laser safety class	Class 1 LED product
Declaration of Compliance with standards	The CE marking of this product applies to "The Electrical Equipment (Safety) Regulations 2006", "The Electromagnetic Compatibility Regulations 2004", the "Waste Electrical and Electronic Equipment Regulations 2006" and the "Equipment and Protective Systems intended for use in Explosive Atmospheres Regulations 1996". [This legislation is the equivalent in UK law of EC directives 2006/95/EC, 2004/108/EC and 2002/96/EC respectively].



The Equipment is declared to meet the provisions of the ATEX directive (94/9/EC) by reason of the EC Type Examination and compliance with the Essential Health and Safety Requirements.

I MacLeod Technical Manager

SPECIAL CONDITIONS FOR SAFE USE

ALL UNUSED CABLE ENTRIES SHALL BE FITTED WITH A BLANKING ELEMENT. THE PERMITTED BLANKING ELEMENTS FOR THE VL34 AND VL35 LUMINAIRES ARE PROVIDED BELOW.

The enclosure has 3x M20 entries into the enclosure via the base, two at one end and one at the other. The luminaries are supplied with two component certified blanking elements. The blanking elements permitted to be used within this product are shown below.

Manufacturer	Type	Certificates Nos.	Temperature Range
Hawke	375	IECEX BAS 06.0056U / Baseefa06ATEX0236U	-60°C to +75°C
	387	IECEX BAS 06.0029U / Baseefa06ATEX0118U	-60°C to +80°C (Nitrile o-ring) -60°C to +160°C (Silicone o-ring)

THE END USER MUST ENSURE THAT A MINIMUM INGRESS PROTECTION OF IP66/67 IS ACHIEVED AT EACH ENTRY TO THE ENCLOSURE BY USE OF A SUITABLE CERTIFIED BLANKING ELEMENT OR CABLE ENTRY DEVICE.

1.0 Introduction

The Victor Vanguard VL34 Helideck Emergency and VL35 Emergency Bulkhead uses an Array of segmented Point Source Lighting (APSL) in the form of an encapsulated strip of light emitting diodes (LEDs) to provide light from mains power. The VL34 Helideck luminaire meets CAA CAP437 specification in terms of both colour and intensity. The LEDs are maintenance free and can last in excess of 50000 hours. They are housed in an aluminium body and glass lens. The control gear is electronic with regulated lamp output. The LEDs work equally well at very low temperatures as they do at high and produce a product with very low overall power consumption. When the VL34 Helideck Emergency & VL35 Emergency is specified for low temperature it should be fitted with a battery pack heater to enable the battery pack to be kept at an optimum temperature for maximum reliability and duration.

VL34 Helideck Emergency & VL35 Emergency Version:

8 x 1W Led	Heater not in operation	Heater in operation
Voltage range AC	110 -254V	
Frequency range Hz	50/60 Hz	
Power Watts 220-254V	18W	28W
Current Amps 220 -254V	80mA	120mA
Power Watts 110-130V	18W	28W
Current Amps 110 -130V	160mA	250mA

The safety limit for surface temperature (T rating) is +/-10% on the rated voltage. Equipment should not be operated continuously at more than +10/-10% of the rated voltage of the control gear.

Batteries	4.8V 4Ah NiCd
Emergency Duration	90 minutes
Emergency Output	100%
Power Factor	0.85 minimum
EMC	EN 61547 EN55015: 2000
Over voltage	400V ac for 1 min
Looping	The looping current is 16A. 4mm ² terminals are standard (6mm ² wiring can be used in the terminals in accordance with the luminaire certificate).
Tamb Storage	-40°C to +50°C
Storage	Luminaires are to be stored in cool dry conditions preventing ingress of moisture and condensation.
LED	The 1W LED used is a class 1 LED product.
Fuse and MCB Ratings	Current consumption of an 8 lamp unit is 80mA. It is recommended that for selection of MCB's users should consult the MCB manufacturer. MCB ratings can vary depending on the manufacturer and type and the size of the installation, i.e. impedance of conductors, however type 'C' breakers are usually suitable. The electronic control gear has an inrush current of 12A for less than 1ms on 230V. These figures are worst case with low resistance connections with short cables and low impedance supplies.

WIRING DIAGRAM SHOWING OPTIONAL HEATER

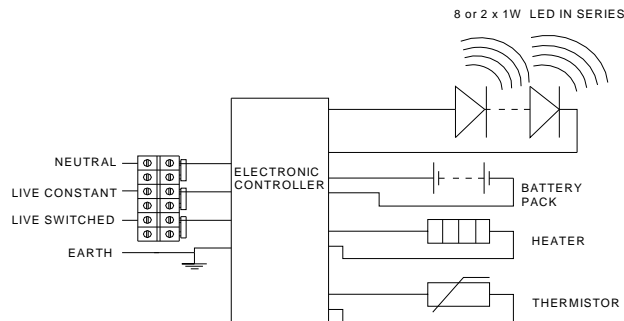

2.0 Installation and Safety

2.1 General

These instructions should be read fully and carefully before attempting to install the luminaire. For details of servicing operations, opening etc. see section 3.0

Copies of these instructions should be held in a safe place for future reference. It is the responsibility of the installer to ensure that the apparatus selected is fit for its intended purpose and that the installation, operation and maintenance of the apparatus complies with applicable regulations, standards or codes of practice.

Installation should be carried out in accordance with *IEC 60079-14* or with a local hazardous area code of practice, whichever is appropriate. Any specific installation instructions must be referred to. In the UK the requirements of the *Health and Safety at Work Act* must be met and electrical work associated with this product must be in accordance with the *"Manual Handling Operations Regulations"* and *"Electricity at Works Regulations 1989"*. Disposal instructions should be complied with.

The luminaires should be considered Class 1 to IEC 60598 and effectively earthed.

2.1.1 Use in Combustible Dust Atmospheres

Where the equipment is used in ignitable dust atmospheres reference must be made to the selection and installation standards in order that the equipment is used correctly. In particular this applies to the derating of surface temperature for use where dust clouds may

be present. Dust layers should not be allowed to accumulate on the fitting surface and good housekeeping is required for safe operation. Dust in layers has the potential to form ignitable clouds and to burn at lower temperatures. Refer to IEC 61241-14 for additional details of selection and installation

2.1.2 Hybrid Mixtures – Gas and Dust

Where hybrid mixtures exist as a potentially explosive atmosphere, consideration should be given to verifying that the maximum surface temperature of the luminaire is below the ignition temperature of the hybrid mixture.

2.2 Tools

Strap wrench, 3mm and 5mm flat blade screwdriver.
Pliers, knife, wire strippers/cutters.
A spanner suitable for fitting cable glands.

2.3 Electrical Supplies

The standard unit is rated for a nominal 110V-254V AC/DC 50/60/0Hz. A maximum voltage variation of +6%/-6% on the nominal is expected. (The safety limit for T rating is +10%). The lamp supply is regulated therefore the light output over the supply range is constant.

The emergency unit can be connected as switched, unswitched or non-maintained. The switching facility is to allow the luminaire to be switched off whilst still charging the battery. Where switching is required, the unswitched line (Lc) is connected to the continuous mains supply. A link is fitted during assembly between Lc and switched line (Ls); this is removed for the switch-able mode. If the link is removed and

Ls not supplied, the unit will only operate on emergency.

2.4 LED Module

This product is fitted with LED lamps that can last in excess of 50000 hours. Therefore in many applications replacement of the LED module will be unnecessary. If replacement is required ensure mains supplies are isolated before commencing work. Undo the 4 bolts securing the lampglass assembly and remove it. Next undo the 4 screws securing the led module to the main body. Disconnect the LED cables from the *terminal block next the earth cable then remove the LED module.

**NOTE: TERMINAL BLOCK SHALL ONLY BE WIRED WITH CABLE IN A TEMPERATURE RANGE OF -10°C TO +80°C*

When refitting the lampglass, ensure that the four lampglass fixing bolts are tightened down fully to compress the sealing gasket**. The lampglass assembly bolts should be tightened gradually to ensure even compression of the gasket**. The design allows metal-to-metal contact between the lamp glass assembly and the main body to ensure even pressure on the gasket**. It is recommended that the bolts be well greased each time the fitting is opened. Ensure the earths are connected and also the gasket**/glass mating surfaces are clean and cables are not trapped.

2.5 Mounting

Luminaires should be installed where access for maintenance is practical and in accordance with any lighting design information provided for the installation. The four 10.3dia holes in the main

body are used to mount the luminaire. Ensure that any fixing screws do not protrude more than 13mm above the surface of the main body shown in section B-B. The luminaire may be mounted in any attitude.

2.6 Re-fitting gaskets**

If the main sealing gasket** needs to be replaced it should be retained in place using a layer of silicone adhesive. The body lip should be cleaned and the adhesive put into the gasket** groove before fitting and clamping down

2.7 Cabling and Cable Glands

2.7.1 Cables

The maximum conductor size is 6mm². Internal earth point is provided next to the main terminal block. 300/500V cable ratings are adequate and no special internal construction is necessary. The standard looping cable size is up to 6mm². The selection of cable size must be suitable for the fuse rating. Terminals are supplied with suitability for looping. Where looping is used the maximum current is 16A. Terminals are accessed by removing the front cover and LED module. Maximum cable temperature rise is 20°C above ambient.

2.7.2 Cable Glands

The installer and user must take responsibility for the selection of cables, cable glands and seals. Three tapped cable entries are provided, two with a plug and seal suitable for permanent use, the other with a travelling plug not suitable for use in service. Sealing plugs are similarly rated and a tool must be used for their removal.

Cable entries are M20x1.5. Cable glands and sealing plugs must have ATEX component approval or be certified to EN 60079-0. For installation outside the EU suitable cable glands in accordance with IEC 60079-0 will meet the technical requirements.

The assembly must maintain a minimum of IP67 rating. The cable glands must be suitable for the application. Where brass cable glands are to be installed, cadmium or nickel plating should be used.

2.8 Emergency Operation

When there is a disruption to the mains supply the Vanguard VL34 Helideck Emergency and VL35 Emergency will switch over to battery backup; as there is no difference in light output this will be signalled by one blink at switchover. Following a full discharge, the LEDs will blink periodically as the batteries regenerate.

2.9 Battery Maintenance

The battery pack is a 4.8V 4Ah NiCad 4 cell pack. Periodic testing allowing full discharge will enable the cells to remain in a healthy condition. Should the battery pack need to be replaced spares may be ordered from Victor Lighting.

The battery assembly must be protected from damage and water ingress then removed from any potentially hazardous area as soon as practical.

The luminaire must not be operated without the battery connected. If the battery is removed and not replaced the control gear supply must be disconnected at the mains terminal block and secured. Care must be taken to connect the positive and negative terminals correctly.

2.9.1 Low temperature operation with battery heater

At temperatures near 0°C ambient the battery heater will switch on. This enables the batteries to be maintained within their optimum temperature range down to -45°C.

3.0 Inspection and Maintenance

Visual inspection should be carried out at a minimum of 12 monthly intervals and more frequently if conditions are severe refer to *IEC/EN 60079-17*.

3.1 Routine Examination

The equipment must be de-energised before opening. Individual organisations will have their own procedures. What follows are guidelines based on *IEC/EN 60079-17* and on our experience:

- 1 Check that the LEDs are working.
- 2 Check the lampglass is not damaged. The lampglass should be kept clean. Wash with water and detergent, rinse with clean water and dry. Do not polish as this may cause static charging.
- 3 When de-energised and left to cool, there should be no significant sign of internal moisture. If there are signs of water ingress, the luminaire should be opened up, dried out, and any likely ingress points eliminated by re-gasketing**.
- 4 Check for loose connections including earthing.
- 5 Check the tightness of the cover screws, glands, blanking plugs, etc.
- 6 Check condition of gaskets** has not softened or become excessively

deformed. If in doubt, replace.

****Note EPDM GASKET NOT TO BE FITTED BELOW - 30°C**

3.2 Electrical Fault Finding and Replacement

Any fault finding must be done by a competent electrician with the luminaire isolated and, if carried out with the luminaire in place, under a permit to work. It is good practice to have substitution parts available for fault finding. Before re-assembling, all connections should be checked and any damaged cable replaced.

3.3 Disposal of Material

Any disposal must satisfy the requirements of the WEEE directive [2002/96/EC] and therefore must not be treated as commercial waste. The unit is mainly made from incombustible materials. The control gear contains plastic resin and electronic components. All electrical components may give off noxious fumes if incinerated.

3.4 Battery Disposal



Nickel cadmium batteries are defined as 'controlled waste' under the hazardous waste regulations and the person disposing needs to observe a 'duty of care'.

Batteries can be returned to the manufacturers for recycling. They must be stored and transported safely and any necessary pollution control forms completed prior to transportation. Take care to fully discharge batteries before transporting, or otherwise ensure that there can be no release of stored energy in transit. For further details refer to our Technical Department.



To comply with the Waste Electrical and Electronic Equipment directive 2002/96/EC the apparatus cannot be classified as commercial waste and as such must be disposed of or recycled in such a manner as to reduce the environmental impact.

Making Hazardous Environments Work

	<p>VICTOR LIGHTING PO Box 5571 Glasgow, G52 9AH Scotland</p>	
<p>Telephone: +44 (0) 141 810 9644 Fax: +44 (0) 141 810 9642 Email: info@victor-lighting.com Web: www.victor-lighting.com</p>	<p>Registered No: 669157 Registered Office: Mitre House, 160 Aldersgate Street, London, EC1A 4DD</p>	

For Technical support, please contact technical@victor-lighting.com

Note: Victor Lighting reserves the right to amend characteristics of our products and all data is for guidance only.