

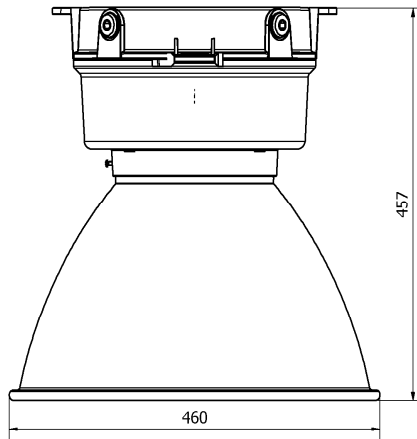

# Monarch II VL15

## INSTALLATION, OPERATION AND MAINTENANCE INSTRUCTIONS

**Important:** Please read these instructions carefully before installing or maintaining this equipment. Good electrical practices should be followed at all times and this data should be used as a guide only.



CEILING MOUNT WITH ENCLOSED REFLECTOR

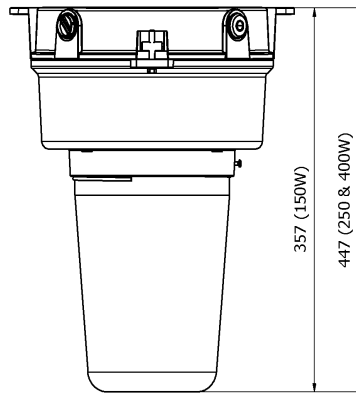

CEILING MOUNT

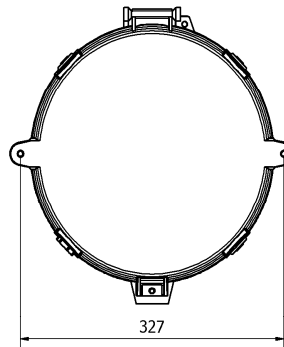
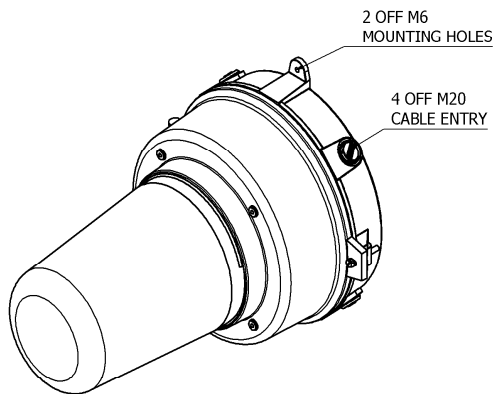

Type Of Protection	EEx nA R (non-sparking) (restricted breathing) to EN 60079-15
ATEX Equipment Classification	Group II Category 3 G
Area of application	Zone 2 areas to BS EN60079-10.
Installation	EN 60079-14
Certificate	Type Examination Baseefa06ATEX0039X
Equipment Coding	⊕ II 3 G EEx nA R II T* (*Refer to Table 1)
Ingress Protection	IP65 to BS EN60529
CE Mark 	The CE marking of this product applies to "The Electrical Equipment (Safety) Regulations 1994", "The Electromagnetic Compatibility Regulations 1992", the "Waste Electrical and Electronic Equipment Regulations 2006" and the "Equipment and Protective Systems intended for use in Explosive Atmospheres Regulations 1996". [This legislation is the equivalent in UK law of EC directives 2006/95/EC, 2004/108/EC and 2002/96/EC respectively].
ATEX Declaration	The Equipment is declared to meet the provisions of the ATEX directive (94/9/EC) by reason of the EC Type Examination and compliance with the Essential Health and Safety Requirements. I MacLeod Technical Manager

### **SPECIAL CONDITIONS FOR SAFE USE**

The wellglasses form a restricted breathing enclosure when fitted in accordance with the manufacturer's instructions. Silicone grease shall be applied to the base of the wellglass or the silicone seal and hand tightened, and then tightened a further 10 degrees.

The symmetrical refractor is suitable only for areas with a low risk of mechanical impact.

#### **1.0 Introduction - MONARCH II Wellglass**

This installation leaflet describes the Monarch II range of ATEX compliant Category 3 Zone 2 wellglass luminaires. The Monarch II is manufactured from painted corrosion resistant aluminium alloy with a toughened glass Globe and silicone rubber gaskets. The integral control gear is contained within an IP65 enclosure and is classified as EEx nA, the lamp chamber is IP65 and is classified as Restricted Breathing EEx nR. The lamp socket may be E27 or E40 dependant on lamp type and power specified. Refer to the following tables for ratings and ambient limitations.

#### **2.0 Application**

The luminaire is designed to be safe in normal operation; type Ex n luminaires should not be operated in an ambient temperature in excess of the rated ambient even for a short period.

The luminaire should not be used in conditions where there are environmental, vibration or shock conditions above the normal for fixed installations.

The gaskets should not be exposed to hydrocarbons in liquid or high concentration vapour states.

The luminaire is suitable for applications where Category 3 apparatus is used. The application is for ignitable gas atmospheres and the presence of combustible dust. The ATEX type examination does not address suitability for portable applications.

#### **3.0 Installation and Safety**

##### **General**

There are no health hazards associated with this product whilst in normal use. However, care should be exercised during the following operations. Installation should be carried out in accordance with BS EN60079-14 or the local hazardous area code of practice, whichever is appropriate.

The luminaires are Class 1 and should be effectively earthed.

Certification details on the rating plate must be verified against the application requirements before installation. The information in this leaflet is correct at the time of publication. The company reserves the right to make specification changes as required.

### 3.1 Tools

Strap wrench, 3mm and 5mm flat blade screwdriver.

Pliers, knife, wire strippers/cutters.

A spanner suitable for fitting cable glands.

### 3.2 Electrical Supplies

The supply voltage and frequency should be specified when ordering a maximum voltage variation of +6%/-6% on the nominal is expected. (The safety limit for T rating is +10%). Luminaires should not be operated continuously at more than +6%/-10% of the rated supply voltage of the control gear or tapping. The user must determine the **actual** underlying site supply and purchase or adjust accordingly. In some cases, the luminaires have multi-tapped control gear which can be set to a range of typical

voltages. Note that ballasts are not dual frequency. The tappings are shown on the control gear and the limits are shown on the rating plate. If the equipment is located in high or low voltage sections of the system, an appropriate voltage tap should be selected to obtain the best lamp performance, but care must be taken to log or mark the equipment so that the tapping is re-set if the equipment is relocated. If in doubt, tappings should be set on the high side. 10V Max. drop is desirable for HPS and required for MBI. All circuits use S.I.P. (superimposed pulse) ignitors. This means that there are only two connections to the choke, so tap selection is obvious. Where supply conditions include significant harmonics, the PFC can be omitted.

Where shore or construction site supplies are used, which are different to the service location supplies, the tappings should be re-set. If not, advice on the effect of these temporary supplies should be sought from the Technical Department.

#### 3.2.1 Fuse Ratings

The fuse ratings for HID lamp circuits need to take account of three components of circuit current. Current inrush to PFC capacitors which can be up to 25 x the rated capacitor current and last 1-2 milliseconds; lamp starting current including steady capacitor current which together may decline from up to 200% of normal at 10 seconds after switch-on to normal after 4 minutes; rectification effects caused by asymmetrical cathode heating for a few seconds after starting, this effect is random and very variable. With the availability of MCB's with a wide range of characteristics, the individual engineer can make a better judgement of what is required. Use MCB's suitable for inrush currents to reduce ratings. The inrush current can be calculated where circuit conditions are known. The nominal capacitor current will probably be the determining factor, 0.076A per  $\mu\text{F}$  at 240V, 50Hz (adjust for other supply volts by multiplication, x 6/5 for 60Hz). For HBC fuses use 1.5 x normal capacitor current. All calculations must satisfy wiring regulations.

### 3.3 Lamps

The discharge lamps used are of a standardised type. There is no preference between make or colour. The Eclipse uses **tubular** HPS and HPS compatible MBI lamps and elliptical MBF lamps. Note that the use of diffuse elliptical lamps may affect photometric performance. Care must be taken to fit the correct new and replacement lamp in order to preserve the certification conditions and obtain the designed photometric performance. The lamp type is shown on the rating plate. **Lamps should be replaced shortly after they do not light.** One indication of the end of life for HPS lamps is 'cycling' where the lamp goes out then re-ignites after a minute or so interval. If discharge luminaires are burned continuously, they should be switched off occasionally to allow old lamps to fail to re-ignite, rather than possibly become diodes with detrimental effects to control gear.

The above information is current at the time of preparation. The development of lamps and control gear is ongoing and detailed advice on lamp performance can be obtained from the lamp supplier or from Chalmite.

**Important:** *HPS and MBI circuits should not be energised without a lamp fitted. HPS and MBI lamps with internal ignitors must not be used.*

### 3.4 Mounting

Luminaires should be installed where access for maintenance is practical and in accordance with any lighting design information provided for the installation. The luminaire is designed to operate at up to an angle of 25° from the vertically down position. The wall mounting or ceiling mounting arrangements should be secured with lock washers or self-locking nuts and bolts. The pole mounting version must be mounted so as to maintain the IP rating.

#### 3.4.1 Fitting the Globe

Care must be taken when fitting the Globe, due to the lamp enclosure being classified as restricted breathing. The following steps must be taken:

- 1 Apply silicone grease to the threads of the Globe.
- 2 Rotate the Globe in the threaded collar until the Globe seals onto the gasket.
- 3 Rotate the Globe until tight; it may be necessary to use a strap wrench to perform this task.
- 4 Secure the Globe using the screw.

### 3.6 Cabling and Cable Glands

#### 3.6.1 Cables

The cable entry temperatures are given as the rise over the maximum rated ambient temperature. This allows the user to adjust the cable specification for actual site maximum temperature. The standard conductor section is 6mm<sup>2</sup> max. All models are suitable for looping except the 400W remote gear version. Standard 300/500V cable is suitable.

#### 3.6.2 Cable Glands

Cable glands for entry into Ex enclosures when fitted with any gland to body sealing method and supply cable, must reliably maintain the IP rating of the enclosure. Nylon washers are provided with the unit to seal between the gland body and the luminaire. The cable glands must be suitable for Zone 2 applications, or the appropriate European Standard for industrial cable entries and cable entry devices. Plastic cable glands must have hazardous area component approval. Where brass cable glands are used nickel plating should be used. Sealing plugs for unused entries should be similarly rated and fitted. Entries suitable for M20 cable glands are standard. Entries suitable for M25 are available to special order.

### 3.7 Cabling and Fitting Lamps

Access for cabling is by undoing the barrel nut using a flat blade screwdriver and rotating until free. Reselect the voltage tapplings if necessary. Install the conductors in the appropriate terminals. Take care not to cut back the insulation excessively, 1mm bare conductor outside the terminal is a maximum. Any unused terminal should be fully tightened.

When the cabling is complete make a final tightness and connection check. The cover is replaced and the screws tightened down.

**Before fitting lamps or opening the luminaire, the luminaire must be de-energised and isolated from the supply.**

The lamp is replaced by removing the Globe, pay close attention to *Section 3.5.1* when replacing the Globe. Lamps must be of the correct type and firmly screwed into place.

### 3.8 Inspection and Maintenance

Visual inspection should be carried out at a minimum of 12 monthly intervals and more frequently if conditions are severe. The time between lamp changes could be very infrequent and this is too long a period without inspection.

#### 3.8.1 Routine Examination

The equipment must be de-energised before opening. Individual organisations will have their own procedures. What follows are guidelines based on *BS EN60079-17* and on our experience:

- 1 Ensure the lamp is lit when energised and that the glass globe is not damaged.
- 2 When de-energised and left to cool, there should be no significant sign of internal moisture. If there are signs of water ingress, the luminaire should be opened up, dried out, and any likely ingress points eliminated by re-gasketing.
- 3 Check the cable gland for tightness.

- 4 Check the tightness of the cover screws.
- 5 Clean the glass globe.
- 6 When re-lamping, check that the Globe gasket has not softened or become excessively deformed. If in doubt, replace (See *Section 3.9*).

### 3.8.2 Electrical Fault Finding and Replacement

The supply must be isolated before opening the luminaire.

In most instances, the faults are simple, namely loose or broken connections, unserviceable lamps or open circuit control gear. Any fault finding must be done by a competent electrician and, if carried out with the luminaire in place, under a permit to work. With HPS and MBI, the ignitor can become faulty. If the lamp is fitted, the choke has continuity and the connections are good and correct, they should produce an attempt to start effect in the lamp and a buzzing sound from the ignitor. It is good practice to have substitution parts available for fault finding. Before re-assembling, all connections should be checked and any damaged cable replaced. The ignition connection to the lampholder is sleeved with H.T. sleeving and this must be kept in place.

### 3.8.3 Thermal Protector

Thermal protectors are included. If the lamp goes on and off over a timescale of several minutes, this may be the thermal protector operating. The causes are defective lamps/diode effects, gross over voltage or the choke beginning to fail and this should be investigated directly.

### 3.9 Overhaul

The unit is largely made of materials that are very corrosion resistant. This allows the unit to be completely stripped, cleaned, and then re-built with new electrical parts as required. The internal wiring is 1.0mm<sup>2</sup> flexible, silicone rubber insulated. An H.T. sleeve is fitted to the ignitor cable. All the spares required are available. Please state the model number, lamp and optical details.

The seal at the end cover is held within a groove by silicone R.T.V. The Globe gasket is similarly held in place by RTV.

If the gaskets have deteriorated by softening or permanent set, new gaskets should be fitted, which can be obtained from Chalmit. To fit the gasket, the old gasket should be removed and remaining RTV scraped off. The gasket is fixed in place and joined with silicone R.T.V. to the body.

## 4 Disposal of Material

The unit is mostly made from incombustible materials. The capacitor is of the dry film type and does not contain PCB's. The control gear contains plastic parts and polyester resin. The ignitor contains electronic components and synthetic resins. All electrical components and the body parts may give off noxious fumes if incinerated. Take care to render these fumes harmless or avoid inhalation. Any local regulations concerning disposal must be complied with. Any disposal must satisfy the requirements of the WEEE directive [2002/96/EC] and therefore must not be treated as commercial waste. The unit is mainly made from incombustible materials. The control gear contains plastic, resin and electronic components. All electrical components may give off noxious fumes if incinerated.

## 5 Lamps

Discharge lamps in modest quantities are not "special waste". The outer envelope should be broken in a container to avoid possible injury from fragmentation Any local regulations concerning disposal must be complied with.

**Important:** Do not incinerate lamps.

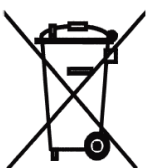

To comply with the Waste Electrical and Electronic Equipment directive 2002/96/EC the apparatus cannot be classified as commercial waste and as such must be disposed of or recycled in such a manner as to reduce the environmental impact.

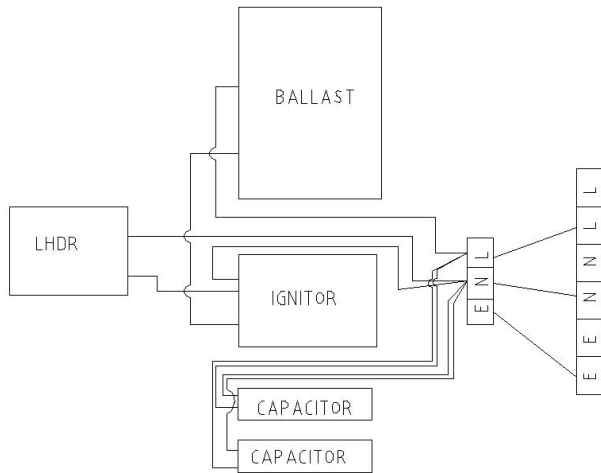

TYPICAL WIRING ARRANGEMENT FOR HPS & MBI LAMPS.

Table 1  
Lamp Ranges, Maximum Ambient and Temperature Ratings with **Globe** optics

Wattage	Lamp	Lamp Cap	Ambient Range °C		T Rating	Max. Surface Temp. °C	Cable Rise °C	Weight kg	Enclosed Reflector		
			Min Ta	Max Ta					T Rating	Max Ta °C	Max Surface Temp °C
50W	SON/T	E27	-45	+55	T4	130	30	7.5			
70W	SON/T, MBI/T										
80W	MBF										
100W	SON/T, MBI/T	E40	-45	+55	T4	135	40	9.0	T3	+55	175
125W	MBF	E27/E40	-20	+45	T3	135	40	8.0			
150W	SON/T, MBI/T	E40	-45	+55	T4	135	40	11.0	T3	+55	175
250W	SON/T, MBI/T			+50	T4	135	35	15.0		+50	
400W	SON/T, MBI/T			+45	T3	160	50	16.0		+35	
250W	MBF		-20	+50	T3	125	40	15.0		+40	180
400W	MBF			+35	T3	160	50	15.5			
400W No PFC	SON/T, MBI/T		-45	+40	T3	160	50	16.0		+40	175

Lamp	Starting and Running Currents			Fuse Ratings Number of Lamps					
	Start A	Run A	PFC uF	1	2	3	4	5	6
50W HPS	0.35	0.28	10	4A	4A	4A	6A	6A	10A
70W HPS/MBI	0.55	0.4	10	4A	4A	4A	6A	6A	10A
80W MBF	0.5	0.43	8	4A	4A	4A	4A	6A	10A
100W HPS/MBI	1	0.56	10	4A	4A	6A	10A	10A	10A
125W MBF	1	0.66	10	4A	6A	6A	10A	10A	10A
150W HPS/MBI	1.2	0.75	15	4A	6A	10A	10A	16A	16A
250W HPS/MBI	2.35	1.35	30	10A	16A	16A	20A	20A	20A
250W MBF	2.35	1.35	20	10A	16A	16A	20A	20A	20A
400W HPS/MBI	4.4	2.2	40	16A	20A	20A	25A	25A	32A
400W MBF	4.4	2.2	25	16A	20A	20A	25A	25A	32A

**Power factor** ≥ 0.85

**EMC** EN 55015

**Terminals** 6mm<sup>2</sup> as standard, looping has current limit of 16A.

**Tamb Storage** -40°C to +80°C

**Storage** Luminaires should be stored in cool dry conditions preventing ingress of moisture and condensation

**Lamps** Tubular lamps with an E27 or E40 cap in accordance with EN 60238

**Fuse and MCB ratings** Refer to table 2 for starting and running currents and fuse ratings. Also refer to section 3.3.1 for information regarding inrush current.

**Making Hazardous Environments Work**

	<p><b>VICTOR LIGHTING</b> PO Box 5571 Glasgow, G52 9AH Scotland</p>	
<p>Telephone: +44 (0) 141 810 9644 Fax: +44 (0) 141 810 9642 Email: <a href="mailto:info@victor-lighting.com">info@victor-lighting.com</a> Web: <a href="http://www.victor-lighting.com">www.victor-lighting.com</a></p>	<p>Registered No: 669157 Registered Office: Mitre House, 160 Aldersgate Street, London, EC1A 4DD</p>	

**For Technical support, please contact [technical@victor-lighting.com](mailto:technical@victor-lighting.com)**

Note: Victor Lighting reserves the right to amend characteristics of our products and all data is for guidance only.