

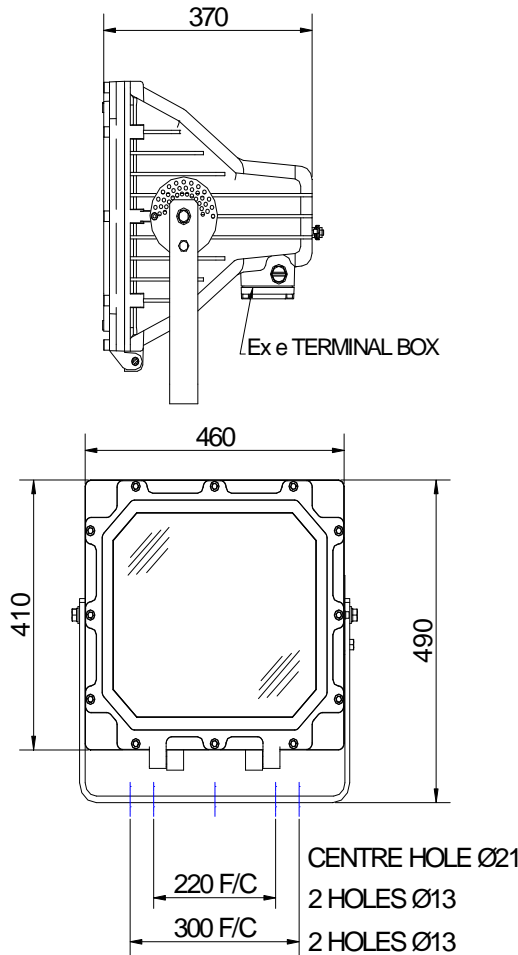

INSTALLATION, OPERATION AND MAINTENANCE INSTRUCTIONS

VL64 EQUAL PLUS

Important: Please read these instructions carefully before installing or maintaining this equipment. Good electrical practices should be followed at all times and this data should be used As a guide only.



0.0 Specification

Type Of Protection	Ex de (flameproof and increased safety)
Protection Standards	(IEC) EN 60079-0, (IEC) EN 60079-1, (IEC) EN 60079-7, (IEC) EN 61241-0, (IEC) EN 61241-1.
ATEX Equipment Classification	Group II Category 2 G
Area Classification	Zone 1 and Zone 2 areas to (IEC) EN 60079-10 and installation to (IEC) EN 60079-14 Zone 21 and Zone 22 areas to (IEC) EN 61241-10 and installation to (IEC) EN 61241-14.
Certificate	EC Type Examination Certificate Baseefa05ATEX0228 IECEX Certificate Number IECEX BAS07. 0052
Equipment Coding	 Ex de IIB T3 Ex tD A21 IP6* T**°C (Refer to table 0)
Ingress Protection	IP66 and IP67 to EN 60529
CE Mark	The CE marking of this product applies to "The Electrical Equipment (Safety) Regulations 1994", "The Electromagnetic Compatibility Regulations 1992", the "Waste Electrical and Electronic equipment Regulations 2006" and the "Equipment and Protective Systems intended for use in Explosive Atmospheres Regulations 1996". [This legislation is the equivalent in UK law of EC directives 2006/95/EC, 2004/108/EC and 2002/96/EC respectively].
ATEX Declaration	The Equipment is declared to meet the provisions of the ATEX directive (94/9/EC) by reason of the EC Type Examination and compliance with the Essential Health and Safety Requirements.
	I MacLeod Technical Manager

SPECIAL CONDITIONS FOR SAFE USE

None

1.0 Introduction – ‘VL64 EQUAL PLUS’ FLOODLIGHT.

The VL64 Equal Plus floodlight is designed for all round lighting applications. It is suitable for use with tubular discharge lamps and single ended tungsten halogen lamps

Note: *Lamp ranges and temperature ratings are outlined in TABLE 0.*

2.0 Storage

Luminaires and control gear boxes are to be stored in cool dry conditions preventing ingress of moisture and condensation. Any specific instructions concerning emergency luminaires must be complied with.

3.0 Installation and Safety

3.1 General

There is no health hazards associated with this product whilst in normal use. However, care should be exercised during the following operations. Installation should be carried out in accordance with (IEC) EN 60079-14 or the local hazardous area code of practice, whichever is appropriate, and fitting of specified insulating material to be adhered to where a specific fire resistance rating is required.

In the UK the requirements of the 'Health and Safety at Work Act' must be met.

Handling and electrical work associated with this product to be in accordance with the 'Manual Handling Operations Regulations' and 'Electricity at Work Regulations, 1989'. Your attention is drawn to the paragraphs (i) 'Electrical Supplies', (ii) 'Electrical Fault Finding and Replacement' and (iii) 'Inspection and Maintenance'. The luminaires are Class 1 and should be effectively earthed.

The luminaires are quite heavy and suitable means of handling on installation must be provided.

Certification details on the rating plate must be verified against the application requirements before installation.

The information in this leaflet is correct at the time of publication. The company reserves the right to make specification changes as required.

3.1.1 Use in Combustible Dust Atmospheres

Where the equipment is used in ignitable dust atmospheres reference must be made to the selection and installation standards in order that the equipment is used correctly. In particular this applies to the de-rating of surface temperature for use where dust clouds may be present. Dust layers should not be allowed to accumulate

on the fitting surface and good housekeeping is required for safe operation. Dust in layers has the potential to form ignitable clouds and to burn at lower temperatures.

Refer to (IEC) EN 61241-14 for additional details of selection, installation and maintenance.

3.1.2 Hybrid Mixtures – Gas plus Dust.

Where Hybrid mixtures exist as defined in EN 1127 as a potentially explosive atmosphere, consideration should be given to verifying that the maximum surface temperature of the luminaire is below the ignition temperature of the hybrid mixture.

3.1.3 Floodlight Orientation in the presence of combustible dust.

The luminaire was tested in accordance with (IEC) EN 61241-1, (IEC) EN 61241-0 practice A.

As the build up of the dust layer can never be guaranteed not to occur, the luminaire must not be mounted in an orientation where the dust could lie on the glass. The temperature on the glass is the hottest point on the luminaire and any obstruction of the radiation from the luminaire would cause the surface temperature to increase.

3.2 Tools

5 and 8mm A/F socket keys.

3mm flat blade screwdriver.

Suitable spanners for installing cable glands.

Pliers, knife, wire strippers/cutters.

3.3 Electrical Supplies

The supply voltage and frequency should be specified when ordering. A maximum voltage variation of +6%/-6% on the nominal is expected. (The safety limit for T rating is +10%). Luminaires should not be operated continuously at more than +6%/-10% of the rated supply voltage of the control gear or tapping. The user must determine the **actual** underlying site supply and purchase or adjust accordingly. **Care must be taken in connecting to the nominal 230V UK public supply.** In most cases, the luminaire has multi-tapped control gear which can be set to a range of voltages on 50 or 60Hz cycles. The tapplings are shown on the control gear and the limits are shown on the rating plate. If the equipment is located in high or low voltage sections of the system, an appropriate voltage tap should be selected, but care must be taken to log or mark the equipment so that the tapping is re-set if the equipment is re-located. If in doubt, tapplings should be set on the high side, 10V max. drop is desirable for HPS. The light output will be reduced. The HPS circuits use S.I.P ignitors and the circuit diagram will indicate the choke connections. Where MBI/Metal Halide lamps are used, the tapping must be set accurately for best performance. Where shore or construction site supplies are used, different to the service supplies, tapplings should be re-set. If not, advice on the effect of these temporary supplies should be sought from the Technical Department. Where adverse system conditions occur, luminaires can be supplied without PFC. The circuit current will then be the lamp current. The circuit power does not change. Incandescent lamps must be selected for the supply voltage. Running at over the rated supply voltage will reduce life and at greater than +10% will compromise the T rating.

3.4 Lamps

The lamps used in this range are of a standardised type, and there is no preference between makes, or in the case of HPS colour. Due to the need to control photometric performance and certification conditions, and avoid incorrect lamps being fitted, the type of lamp and size is specified on the rating plate. If mixed installations are used, care must be taken to ensure that the correct lamp is fitted on installation and replacement.

HPS lamps substantially maintain their light output to the end of their electrical half life, which can be up to 24,000 hours. However, lamp replacement at around 16,000 hours is desirable to avoid piecemeal replacement on a large scale. **HPS and MBI lamps should be replaced shortly after they do not light.** One indication of the end of life for HPS lamps is 'cycling' where the lamp goes out then re-ignites after a minute or so interval. If discharge luminaires are burned continuously they should be switched off occasionally, to allow old lamps to fail to re-ignite rather than possibly become diodes with detrimental effects on control gear. The above information is current at the time of publication. The development of lamps and control gear is ongoing and detailed advice on lamp performance can be obtained from the Technical Department or the lamp

supplier. **HPS and MBI circuits should not be energised without a lamp fitted.** HPS lamps without an internal ignitor should be used. The current HPS control gear is incompatible with internal ignitor lamps.

3.5 Mounting

Luminaires should be installed where access for maintenance is practical and in accordance with any lighting design information provided for the installation. This will usually consist of aiming points and aiming angles.

Mounting arrangements should be secured with lock washers or self-locking nuts and bolts.

3.6 Cabling and Cable Glands

3.6.1 Cable Glands

The installer and user take responsibility for the selection of cables, cable glands and seals.

The product is certified for ATEX and to comply with the certification for installation and use within the EU, cable glands and sealing plugs must have ATEX component approval.

For installation outside the EU, suitable cable glands in accordance with (IEC) EN 60079-0 will meet the technical requirements.

The cable and gland assembly when installed must maintain the IP66/67 rating of the luminaire.

The cable gland must withstand an impact value of 7Nm where the risk of mechanical damage is high or 4Nm where the risk of mechanical damage is low.

Sealing plugs must be similarly rated and a tool must be used for their removal. Where the cable is not reliably clamped externally to the apparatus, the cable gland must clamp the cable against a pull in Newtons of 20 x the cable OD in mm for non-armoured cable and 80 x the cable OD for armoured cable. Where brass cable glands are used in a corrosive environment cadmium or nickel plating should be used. Two tapped cable entries are provided, one with a plug and seal suitable for permanent use, the other has a travelling plug. M20 x 1.5 entries are standard, other sizes are available on request.

3.6.2 Cable

At maximum rated ambient temperature refer to rating table for minimum cable temperature rating. The luminaire is also rated with the temperature rise at the cable entry. This allows the user to adjust the cable spec. for an **actual** T amb lower than that for which the luminaire is certified. The standard looping conductor size is 6mm².

Internal and external earth points are provided. For luminaires specified for non-standard ambient temperatures refer to the Technical Department.

300/500V cable ratings are adequate and no special internal construction is necessary as the terminations are Ex e. The selection of cable size will be suitable for the fuse rating. Some guidance on this is given below. When MCB's are used, the type with the higher inrush current resistance, as used for motor starting and lighting, should be specified.

3.6.3 Cable Connection

The cable connections are made by removing the terminal chamber cover. The retaining screws are captive and should be re-greased as required. No more than one single or multiple strand lead shall be connected into either side of any terminal, unless multiple conductors have been joined in a suitable manner, e.g. two conductors into a single insulated crimped bootlace ferrule. Leads connected to the terminals shall be insulated for the appropriate voltage and this insulation shall extend to within 1mm of the metal of the terminal throat. All terminal screws, used and unused, shall be tightened down to between 1.2 Nm and 2 Nm. The core must be identified by polarity and connected in accordance with the terminal markings. Before re-fitting the cover, a final check on the correctness of connections should be made. Ex e cover bolt torque 6Nm. Where control gear tappings need to be re-selected, the lampglass needs to be removed (see below). Undo the eight screws to remove front cover and remove the reflector by removing three fixing screws, then re-select the taps (see 'Electrical Supplies' above).

3.7 Fitting Lamps

Make sure the correct lamp is selected as detailed above. Access for fitting lamps is gained through the lampglass cover. The lamp should be firmly screwed into place. The flameproof path should have a coat of silicone grease (Dow Corning "Molykote III" or similar) or other protective non-setting grease suitable for high temperature. Replace all bolts and fully tighten. Lamp glass cover bolt torque 24Nm.

3.8 Inspection and Maintenance

Visual inspection should be carried out at a minimum of 12 monthly intervals and more frequently if conditions are severe, refer to (IEC) EN 60079-17. The time between lamp changes could be very infrequent and this is too long a period without inspection.

3.8.1 Routine Examination

The equipment must be de-energised before opening and note taken of the rated opening delay periods alternatively the nameplate may read 'do not open when an explosive gas atmosphere is present'. Individual organisations will have their own procedures. What follows are guidelines based on (IEC) EN 60079-17 and on our experience:

- 1 Ensure the lamp is lit when energised and that the lampglass is not damaged.
- 2 When de-energised and left to cool there should be no significant sign of internal moisture. If there are signs of water ingress, the luminaire should be opened up, dried out, and any likely ingress points eliminated by re-gasketing, re-greasing or other replacement.
- 3 Check the terminal chamber bolts for tightness. Torque 6Nm.
- 4 Check the cable gland for tightness and tighten if necessary.
- 5 Check any external earthing.
- 6 Examine the glass for any signs of sealant damage, cracking or discoloration. If thought necessary, the silicone weather seal can be re-sealed with a proprietary brand of clear RTV silicone, but only if the underlying sealant is in good condition.
- 7 Check all cover bolts for tightness. Torque 24Nm.
- 8 Check for signs of corrosion between the glass cover and the main housing. Evaluation of this will be a matter for judgement gained by experience, as there may be little evidence on the outside. If there is any sign of corrosion, remove the cover and wipe the flameproof paths with a clean cloth and non-metallic scraper. Examine the surfaces for pitting; any pitted component should be replaced. A damaged or non-resilient gasket must be replaced. The cord is 4mmØ. The cover should be re-greased with silicone (Dow Corning 'Molykote III' or similar) or other non-setting grease suitable for high temperatures, and re-fitted with all bolts fully tightened. Any replacement bolts must be identical to the original. All are 18/8 stainless steel with a minimum of ISO262 grade A2-70. With this type of flameproof path all bolts must be in place and tight. The maximum gap for IIB in this case is 0.15mm. It will be unusual for any luminaire to have a gap of more than 0.1mm when tried with a feeler gauge. If 0.1mm is exceeded, check that no foreign bodies or debris at the bottom of the blind tapped holes is keeping the surfaces apart and, if not, a workshop overhaul should be carried out to bring the apparatus to as new condition. Periodically, when the lampglass is removed, the opportunity should be taken to remove the reflector, check the lampholder connections for signs of over-heating and similarly check the control gear.
- 9 The terminal chamber should be opened periodically and checked for moisture and dirt ingress. The cable connections should be checked for tightness. The gasket should be checked for cracks or lack of elasticity, and if necessary, replaced. (It may well be practical to also replace the gasket on each occasion if this is at a 3-year interval). Torque 6Nm.
- 10 If painting operations have taken place around the luminaire, ensure that coatings have not entered the flameproof path or been deposited on the lampglass. If they have, dismantle and clean carefully.
- 11 Check that mountings are secure.
- 12 Cover the bolt heads with silicone grease to prevent corrosion and accumulation of dirt in the screw threads.
- 13 Clean the lampglass.
- 14 If there is suspicion that the luminaire has suffered mechanical damage, a stringent workshop check should be made.

Important:

*Where spares are needed, these must be replaced with manufacturers parts.
No modifications should be made without the knowledge and approval of the manufacturer.*

3.9 Electrical Fault Finding and Replacement

The supply must be isolated before opening the luminaire.

Control gear will not normally go open circuit unless it has overheated first and the signs of this are obvious, being severe discoloration of the paint on the gear and cracks in any exposed insulation. Similarly, a bad contact at the lamp cap will usually result in signs of overheating. Any fault finding must be done by a competent electrician and, if carried out with the luminaire in place, under a permit to work.

With HPS and MBI lamps the ignitor can become faulty. If the lamp is fitted, the choke has continuity and the connections are good and correct, they should produce an 'attempt to start' effect and a buzzing sound from the ignitor. It will be unusual to have no other parts available to perform a substitution fault finding routine and this is the normal procedure. Before re-assembling, all connections should be checked and any damaged cable replaced. The ignition connection to the lampholder is sleeved with a high temperature silicone sleeve and this must be kept in place.

4.0 Fuse Ratings

The fuse ratings for HID lamp circuits need to take account of three components of circuit current. Current inrush to PFC capacitors which can be up to 25 x the rated capacitor current, and last 1-2 milliseconds. Lamp starting current including steady capacitor current which together may decline from up to 200% of normal at 10 seconds after switch-on to normal after 4 minutes; rectification effects caused by asymmetrical cathode heating for a few seconds after starting, this effect is random and very variable.

With the availability of MCB's with a wide range of characteristics, the individual engineer can make a better judgement of what is required. Use MCB's suitable for inrush currents to reduce ratings. The normal capacitor current, will probably be the determining factor, 0.076A per µF at 240V, 50Hz (adjust for other volts by multiplication, x 6/5 for 60Hz). For HBC fuses use 1.5 x normal capacitor current. For GLS inrush use 6 x rated current. All calculations must satisfy wiring regulations.

Note: Starting and running currents for 240V, 50Hz are as indicated in TABLE 1.
A conventional matrix for HBC fuses is shown in TABLE 2.

5.0 Disposal of Material

Any disposal must satisfy the requirements of the WEEE directive [2002/96/EC] and therefore must not be treated as commercial waste. The unit is mostly made from incombustible materials. The control gear contains plastic, resin and electronic components. All electrical components may give off noxious fumes if incinerated.

5.1 Lamps

Incandescent lamps and discharge lamps in modest quantities are not "special waste". The outer envelope should be broken in a container to avoid possible injury by fragmentation.

This applies to the UK, there may be other regulations on disposal operating in other countries.

Important: Do not incinerate lamps.



To comply with the Waste Electrical and Electronic Equipment directive 2002/96/EC the apparatus cannot be classified as commercial waste and as such must be disposed of or recycled in such a manner as to reduce the environmental impact.

Tables 0/1/2

Table 0 Lamp Ranges and Temperature Ratings					Ref to Section : 1.0			
Lamp	Wattage	Rated Supply	T Class	T amb °C	Min Amb °C	Dust Rating °C	Rated Cable °C	Cable Rise Above Amb °C
T/HAL	500	110-250V	T3	55	-20°C	175	85	30
SON/T	400	220-277V	T3	55		175	95	40
	250		T4	55		128	75	20
	250		T3	70		145	90	20
	150		T4	70		128	85	15
MBI	400	50/60 Hz	T3	55		160	90	35
	250		T4	55		128	75	20
	250		T3	70		145	90	20
	150		T4	70		128	85	15

Table 1		Starting and Running Currents			Refer to section : 4.0	
LAMP	Lamp A	Start A	Run A	Capacitance μ F	Circuit Power (W)	
150W SON/T	1.8	1.45	0.8	20	175	
250W SON/T	3.0	2.35	1.3	30	285	
400W SON/T	4.6	4.0	2.2	40	445	
150W MBI	1.8	1.6	0.8	20	175	
250W MBI	3.0	2.7	1.35	30	285	
400W MBI	4.2	4.0	2.2	40	445	

Notes: Minimum power factor correction: 0.85.
The start and running currents are corrected.

Table 2		Fuse Ratings					Refer to section : 4.0	
Lamp	Number of Lamps							
	1	2	3	4	5	6		
150W	4A	6A	10A	10A	16A	16A		
250W	10A	16A	16A	20A	20A	20A		
400W	16A	20A	20A	25A	25A	32A		

Making Hazardous Environments Work

	<p>VICTOR LIGHTING PO Box 5571 Glasgow, G52 9AH Scotland</p>	
<p>Telephone: +44 (0) 141 810 9644 Fax: +44 (0) 141 810 9642 Email: info@victor-lighting.com Web: www.victor-lighting.com</p>	<p>Registered No: 669157 Registered Office: Mitre House, 160 Aldersgate Street, London, EC1A 4DD</p>	

For Technical support, please contact technical@victor-lighting.com

Note: Victor Lighting reserves the right to amend characteristics of our products and all data is for guidance only.